

SECTION A-A

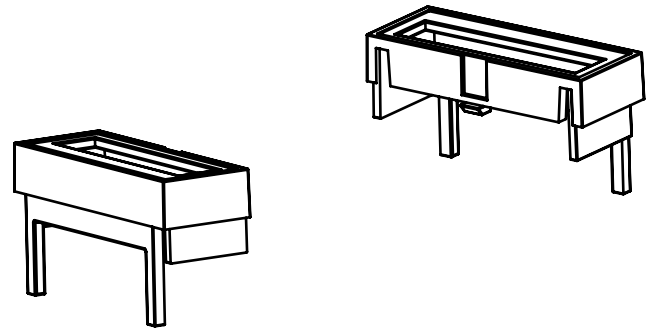

General information:
 - Workpiece zero point for mechanical processing
 - Minimum recommended radius for machining = R1.0 mm

General Tolerance UNI EN 22768/1 Media (m)					Sheet:	
from 0.5 to 3 ± 0.1	from 3 to 6 ± 0.1	from 6 to 30 ± 0.2	from 30 to 120 ± 0.3	from 120 to 400 ± 0.5	1	
Scale: 1:1	Drawn: M.S.	Checked: R.N.	Date: 13/06/2023	Material: PC/ABS	Process: INJECTION	
Dimension in mm		Derived from: --	Weight: 1.85 gr		Cod. Mold: ST.05CN002	
italtronic enclosures for electronics italtronic.com					Description: COPRIMORSETTO PREFORATO PASSO 9,52 3 VIE 2MP9,52ICOPRIMORSETTO PREFORATO PA TERMINAL COVER MODULBOX PRE-HOLED 2MP9,52I PITCH 9,52 3 POLES	
Drawing nr.: 2_250_03744				Rev.: 00 A4		